

CAD FILE:

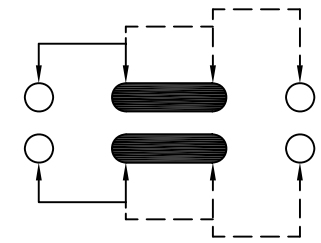

SCHEMATIC (NON-SHORTING)

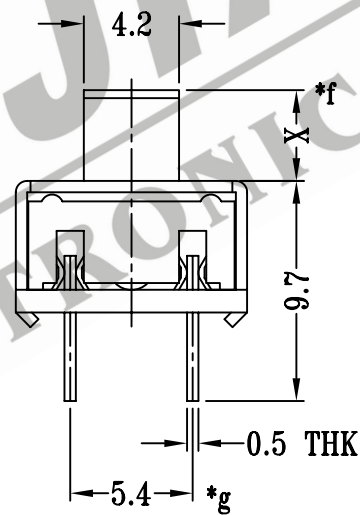
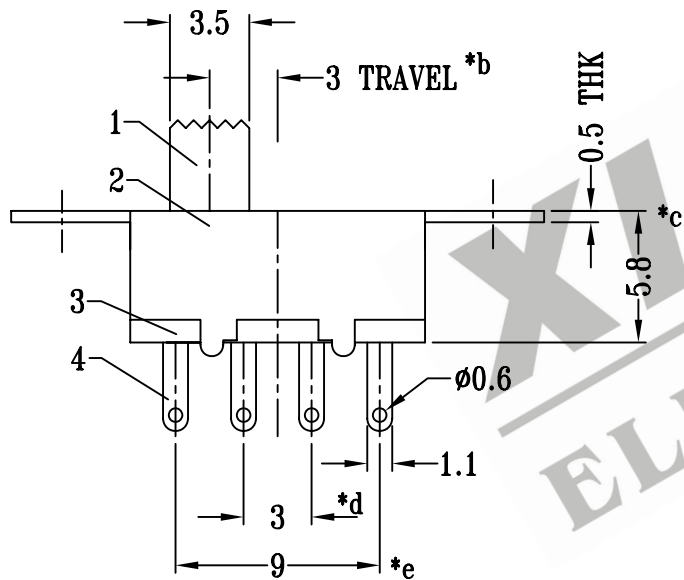
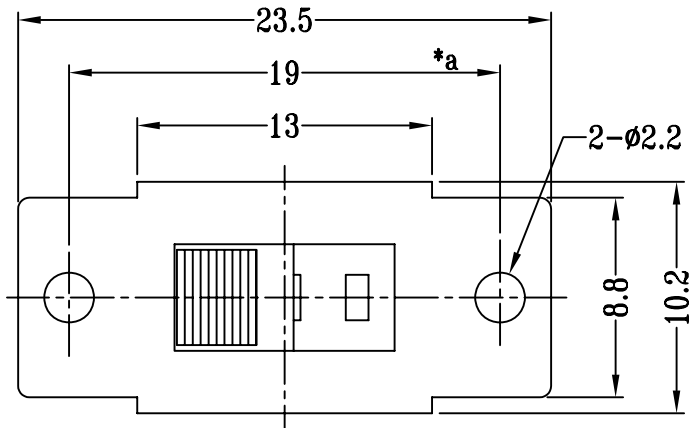
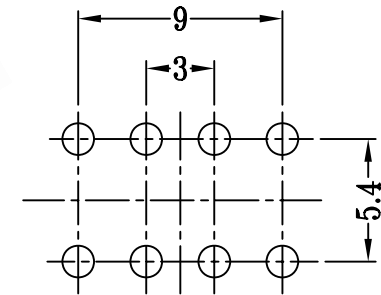

P.C.B LAYOUT

注:带"*"表示关键尺寸(6个)

NO.	PARTS	MATERIALS	Q'TY	FINISH	TOLERANCE UNLESS SPECIFIED	SHENZHEN XIEJIA ELECTRONICS CO.,LTD.				
8						ISSUE	DATE	DESCRIPTIONS OF REVISION		APPD.
7	STEEL BALL	STEEL	1	NATURAL	WITHIN: 1.5±0.1mm OVER: 1.5±0.2mm					
6	SPRING	STEEL WIRE	1	TEMPER		UNIT: mm		DRWG NO.: XJ-DR-SS23F26-00		
5	CONTACT CLIP	PBS STRIP	2	Ag PLATED		SCALE: 3:1		DWN.	ZHOUYU	2005-11-24
4	TERMINAL	BRASS STRIP	8	Ag PLATED OVER Ni PLATED	TITLE: VERTICAL SLIDE SWITCH			CHK'D	FANGYING	2005-11-24
3	BASE	PHENOLIC RESIN	1	NATURAL	MODEL: SS-23F26			APPD.	KANGXINAN	2005-11-24
2	FRAME	STEEL STRIP	1	Ni PLATED	ALL MATERIALS MUST BE COMPLIANT TO ROHS					
1	KNOB	POM	1	BLACK						